

LUG TİP KELEBEK VANA

- Lug Tip Kelebek Vana
- Teknik Özellikleri
- Uygulama Alanları
- Aktüatör Çeşitleri
- Teknik Detay





TKC

directs to fluid

TKC ENDÜSTRİYEL ÜRÜNLER VE
YAPI MALZEMELERİ SAN. TİC. LTD. ŞTİ

LUG TİP KELEBEK VANA



TEKNİK ÖZELLİKLER

Gövde

GG25, GGG40

Klape

Nikel, AISI 304, AISI 316, AL-BRONZ

Conta

EPDM, NBR, PTFE, VİTON

Max Çalışma Basıncı

16 Bar

Max Çalışma Sıcaklığı

EPDM (120°C)

NBR (110°C)

PTFE (150°C)

VİTON (200°C)

AKTÜATÖR ÇEŞİTLERİ

- Dişli Kutullu (Redüktörlü)
- Tek Etkili Pnömatik Aktüatörlü
- Çift Etkili Pnömatik Aktüatörlü
- Elektrik Aktüatörlü / 220V AC On/Off - 24V DC On/Off

LUG TİP KELEBEK VANA NEDİR?

Kelebek vanalar; gaz, sıvı, parçalı veya viskoz gibi akışkanları kontrol altında tutmak için kullanılan kompakt yapılı, sızdırmazlık sağlayan ve diğer vanalara göre çok daha az yer kaplayan bir vana çeşididir. Kelebek vanalar, tesisatlara ve borulara farklı şekilde montaj edilmektedir.

Lug bağlantı modeline göre monte edilen vanalar, kelebek vanaların u zerinde bulunan lug bağlantı kulakları ile monte edilir. Vanada bulunan kulakların iç yapıları dişlidir. Lug kelebek vanaları, tesisatların her bölgesinde kullanıldığı gibi hat sonlarında da kullanılmaktadır.

UYGULAMA ALANLARI

- Isıtma, havalandırma ve iklimlendirmesistemleri
- Su arıtma ve dağıtım sistemleri
- Maden sanayii
- Gemi inşaatı ve sondaj tesisleri
- Şeker sanayi, gıda ve kimya işletmeleri
- Yangın söndürme sistemleri
- Su, deniz suyu, toz, gaz, atık su ve hava

İkitelli O.S.B. Trios 2023 İş Merkezi B Blok Kat:3 No:143
Başakşehir / İSTANBUL

+90 212 854 05 70

info@tkc.com.tr

www.tkc.com.tr



TKC

directs to fluid





TKC

directs to fluid

TKC ENDÜSTRİYEL ÜRÜNLER VE YAPI MALZEMELERİ SAN. TİC. LTD. ŞTİ

Teknik Detay

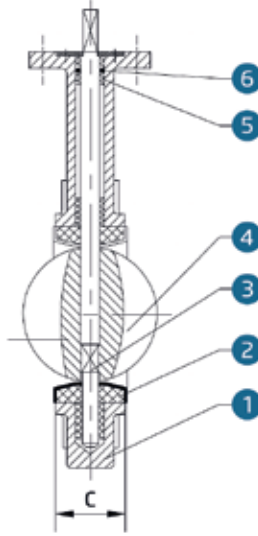
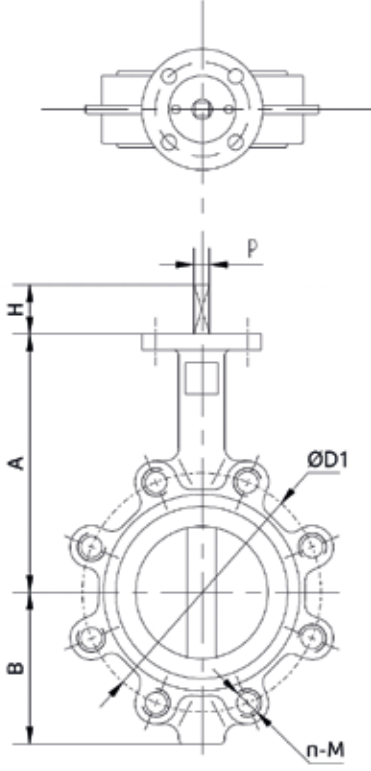

ITEM	PART NAME	MATERIAL
1	Body	GG25, GGG40
2	Seat	EPDM, NBR, PTFE, VITON
3	Shaft	SS416
4	Disc	GGG40 / CF8 / CF8M / AL-BRONZ
5	Bushing	PTFE
6	O Ring	NBR
7	Lever / Gear	

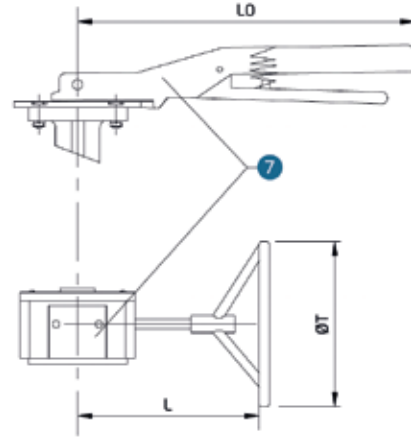

in	DN	A	B	H	P	C	UP FLANGE ISO 5211	L0	T	L	PN10		PN16		5K	
											D1	n-M	D1	n-M	D1	n-M
1.5	40	125	68	30	9	33	F05	215	137	150	110	4-M16	110	4-M16	95	4-M12
2	50	129	73	30	9	42	F05	215	137	150	125	4-M16	125	4-M16	105	4-M12
2.5	65	137	82	30	9	44.7	F05	215	137	150	145	8-M16	145	8-M16	130	4-M12
3	80	144	95	30	9	45.2	F05	215	137	150	160	8-M16	160	8-M16	145	4-M16
4	100	163	109	30	11	52.1	F07	260	137	150	180	8-M16	180	8-M16	165	8-M16
5	125	179	125	30	14	54.4	F07	260	137	150	210	8-M16	210	8-M16	200	8-M16
6	150	198	144	30	14	55.8	F07	260	137	150	240	8-M20	240	8-M20	230	8-M16
8	200	237	173	30	17	60.6	F10	355	269	207	295	8-M20	295	12-M20	280	8-M20
10	250	281	211	30	22	65.6	F10	355	269	207	350	12-M20	355	12-M24	345	12-M20
12	300	318	244	30	22	76.9	F10	355	269	207	400	12-M20	410	12-M24	390	12-M20



İkitelli O.S.B. Trios 2023 İş Merkezi B Blok Kat:3 No:143
Başakşehir / İSTANBUL



+90 212 854 05 70



info@tkc.com.tr



www.tkc.com.tr



TKC

directs to fluid





TKC

directs to fluid

TKC ENDÜSTRİYEL ÜRÜNLER VE
YAPI MALZEMELERİ SAN. TİC. LTD. ŞTİ

Teknik Detay

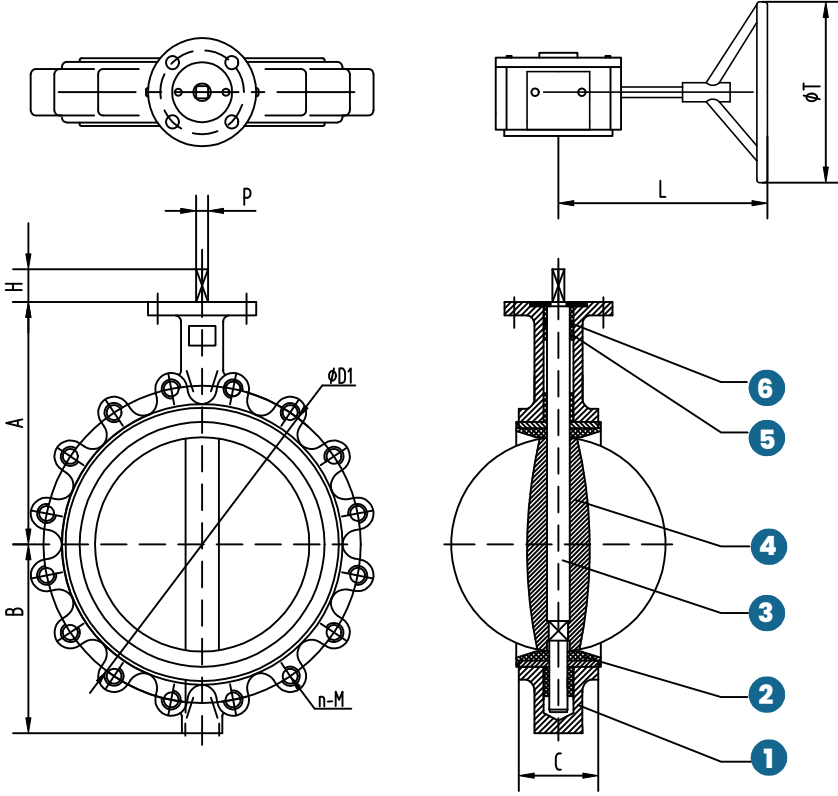

ITEM	PART NAME	MATERIAL
1	Body	GG25, GGG40
2	Seat	EPDM
3	Shaft	SS416
4	Disc	CF8M
5	Bushing	PTFE
6	O Ring	NBR
7	Lever / Gear	

INCH	DN	A	B	H	P	C	UP FLANGE		FLANGE PN16		WEIGHT
							ISO 5211	T L	D1	n-M	
14	350	368	267	45	27	76.9	F10	269 195	470 16-M24	50	
16	400	400	309	50	27	86.5	F14	380 250	525 16-M27	69	
20	500	480	380	50	27	127	F14	380 250	650 20-M30	128	

İkitelli O.S.B. Trios 2023 İş Merkezi B Blok Kat:3 No:143
Başakşehir / İSTANBUL

+90 212 854 05 70

info@tkc.com.tr

www.tkc.com.tr



TKC

directs to fluid

